

## BOTTOM WELD PLATES

### WITH WIRE LOOPS

As part of a program for evaluating various inserts used in Spancrete® hollowcore plank, weld plates as shown below were tested in the bottom of some plank. The plates were located on the casting bed at a strand location and tied securely to the strand prior to placing concrete.

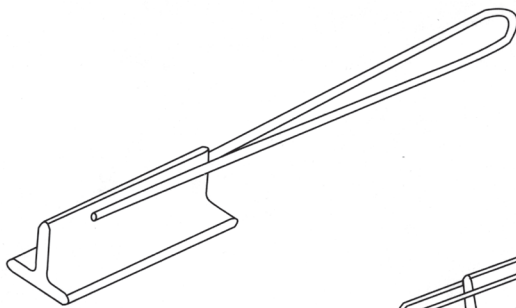

**BWA-5**  
 Tee 1 1/2" x 1/4" x 4"  
 with 1/4" smooth bar  
 x 18" long

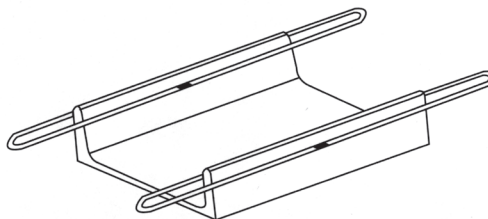

**BWA-6**  
 Channel 4" x 5.4# x 6"  
 with 1/4" x 10" loops

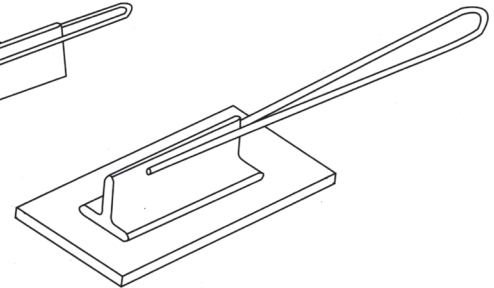

**BWA-8**  
 BWA-5 anchor welded  
 to plate 3/8" x 4" x 8"

### SUMMARY OF TEST RESULTS (IN KIPS)

First value given is average test capacity. Second value given is lowest test capacity.

INSERT	P <sub>1</sub>	P <sub>2</sub>	P <sub>3</sub>	P <sub>4</sub>	V <sub>1</sub>	V <sub>2</sub>	V <sub>3</sub>	V <sub>4</sub>	V <sub>5</sub>	V <sub>6</sub>
BWA-5	3.2	5.9	1.5	3.2	13.3	6.3	14.8	2.2	1.1	2.7
	2.7	5.5	1.3	3.0	8.2	5.6	11.2	1.9	.72	1.7
BWA-6	7.8	12.2	5.0	7.2	32.7	26.6	32.0	12.4	5.5	11.0
	7.5	12.0	3.4	7.0	31.0	24.7	31.0	8.3	4.9	9.4
BWA-8	6.3	5.4	-	-	-	-	-	-	-	-
	5.8	4.5	-	-	-	-	-	-	-	-

**Note:** Values given are test results. Appropriate strength reduction factors and safety factors must be applied to these values. Consideration should be given to the number of tests and the inconsistencies in results of the concrete failures when determining these factors.

This research was done using 40" wide, 8" thick Standard Spancrete. However, this concept applies to all Spancrete cross sections.

**BOTTOM WELD PLATE TEST SETUP (WIRE LOOPS)**

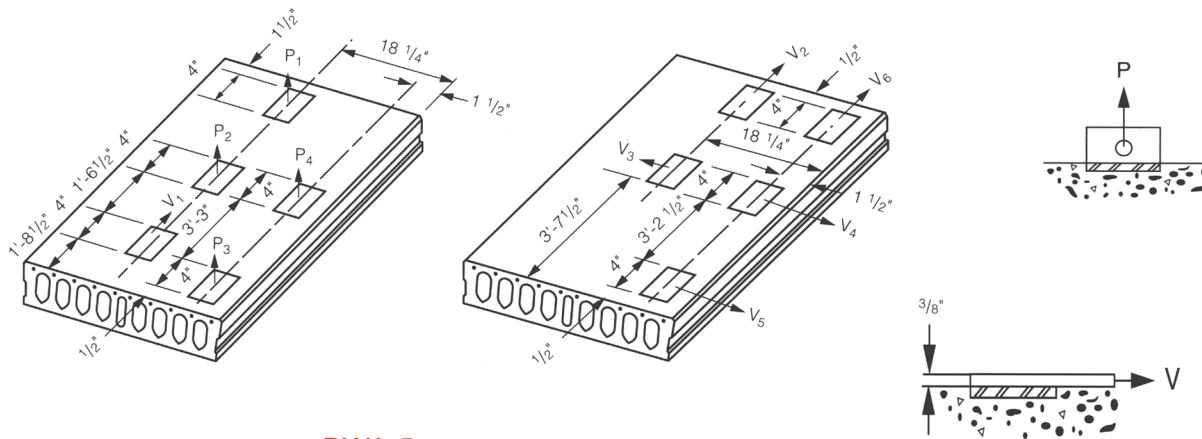

**BWA-5**

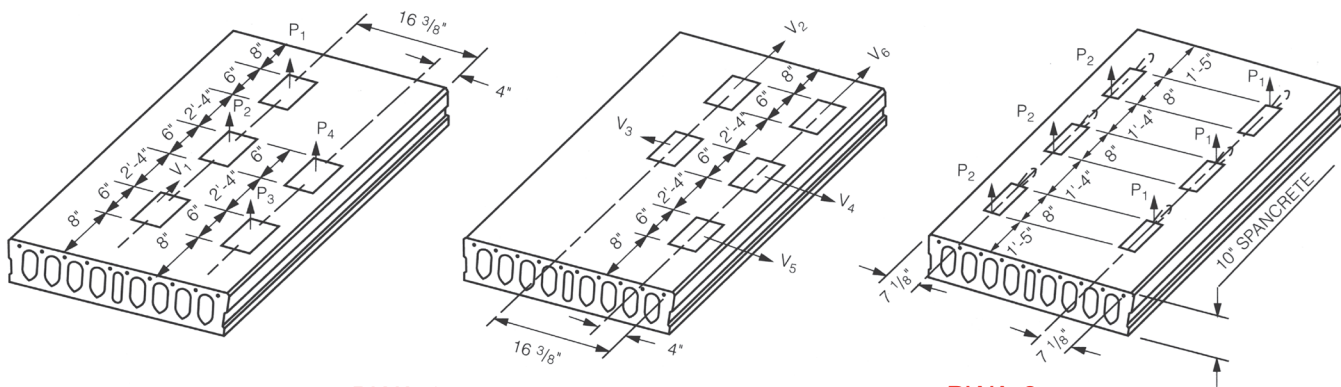

**BWA-6**

**BWA-8**

**MIDWEST**

Hanson Structural  
Precast Midwest, Inc.  
Maple Grove, Minnesota

Spancrete, Inc.  
Green Bay, Wisconsin

Spancrete Industries, Inc.  
Waukesha, Wisconsin

Spancrete of Illinois, Inc.  
Arlington Heights, Illinois

Wells Concrete  
Wells, Minnesota

**WEST**

Hanson Structural  
Precast Pacific, Inc.  
Irwindale, California

**KIE-CON**

Division of Kiewit Pacific Co.  
Anitoch, California

Owell Precast  
Sandy, Utah

**SOUTHWEST**

Manco Structures, Ltd.  
Schertz, Texas

**SOUTH**

Cement Industries, Inc.  
Fort Myers, Florida

Florida Precast Industries, Inc.  
Sebring, Florida

**EAST**

Mid-Atlantic Precast, LLC.  
King George, Virginia

**EGYPT**

Samcrete Egypt  
Ahram, Giza

**MEXICO**

ITISA  
Mexico City, Mexico

Spancrete Noreste  
Monterrey, Mexico

**CROATIA**

Mucic & Co  
Dugopolje, Croatia

**CARIBBEAN**

Preconco Limited  
Barbados, West Indies

**TURKEY**

Yapi-Merkezi  
Camlica-Istanbul, Turkey

**UAE**

Hi-Tech Concrete  
Products LLC  
Abu Dhabi, UAE

**MACHINE**

MANUFACTURER  
Spancrete Machinery  
Corporation

N16 W23415 Stoneridge Drive  
Waukesha, WI 53188  
Telephone: 414-290-9000  
Fax: 414-290-9130  
www.spancrete-machinery.com

**SPANCRETE IS ALSO  
MANUFACTURED IN:**

Armenia	Ireland
China	Japan
Denmark	Russia
Guatemala	South Korea
Hungary	Switzerland

Spancrete® hollowcore is a registered trademark